

VOTRONIC

Installation and Operating Manual

MobilPOWER Inverter SMI 600 Sinus

No. 3157

Inverter 12 V DC / 230 V AC for application in special purpose vehicles, high-quality campers as well as in the marine field.

The sine inverters convert 12 V Direct Voltage (DC) of a battery into 230 V / 50 Hz Sinusoidal Alternating Voltage (AC) in quality of mains voltage.

The **MobilPOWER Inverters Sinus** are the ideal solution for operation of high-quality **230 V mains consumers**, such as B.BOS, hand lamps, battery chargers, radio systems and high-quality audio systems, video, PDA, Laptop, computer, energy-saving lamps, TV, satellite systems, E-Bike chargers etc., up to capacity rates of 600 Watts **being supplied by the 12 V board mains supply**.

The units are designed according to the state of the art in clock pulse-controlled execution ("switch mode"). Due to the microprocessor control combined with advanced SMD technology a compact design could be realized. Easily running fans (with speed control) being noise-optimised and friction-optimised ensure perfect cooling and thus unproblematic continuous operation, even at full capacity.

Furthermore, the thermal and electric load as well as overload and short-circuit of the output circuit are supervised by integrated protective circuits.

The inverters are equipped with an intelligent control for power saving with automatic disconnection, which ensures minimised power consumption during idle time.

An integrated undervoltage protection protects the batteries by disconnecting the inverter in case of dropped battery voltage.

Features:

- Output voltage in quality of mains voltage (**pure sine**)
- Output frequency crystal stabilized 50 Hz
- Control for power saving with automatic disconnection (automatic mode)
- The display panel can be rotated by 360 °, and it can be used as remote control
- Solid dimensioning, robust and compact design, high operating safety
- Automatic protective disconnection in case of low voltage of the battery
- Automatic protective disconnection in case of overvoltage of the battery
- Electronic and thermal overload protection
- Intelligent microprocessor control
- Clock-pulse controlled execution, high frequency (switch mode)
- High efficiency (approx. 90 %)
- A connection cable of a length of 1.2 m with thread is already installed at the unit.
- Continuous cooling fan with temperature control and control of the fan-in current



Please read these assembly and operating instructions and in particular the safety instructions on page 2 before starting the connection and start-up.



Safety Instructions

Appropriate Application:

The inverter has been designed according to the valid safety regulations.

Appropriate application is restricted to:

1. **At lead acid, gel or AGM batteries as well as LiFePO4 batteries of the specified rated voltage in fixed installed systems. The specified minimum battery capacity must be observed.**
2. **For supplying mains voltage devices up to the specified maximum power.**
3. **With battery connection cable of the recommended minimum cross-section and maximum length.**
4. **Technically faultless condition.**
5. **Installation in rooms being protected from rain, humidity, dust, aggressive battery gas, as well as in an environment being free from condensation water.**
6. **If the driver and other road users are not affected.**

- **Never use the unit at locations where the risk of gas or dust explosion exists!**
- **The inverter is to be equipped with a fuse for protection of the battery cables.**
- Open-air operation of the unit is not allowed. For installation in vehicles the valid VDE safety regulations are to be observed!
- Handling of units being connected to the inverter is to be effected as careful, as if the units were connected to the local mains supply. In case of potential hazardous situations, the inverter is to be switched-off immediately, or the consumer is to be separated from the inverter.
- Never open units being connected to the inverter, neither when the inverter has been switched-off, nor when it is separated from the battery.
- Never connect supply voltage, an AC generator or an additional inverter to the socket of the inverter, otherwise the unit might be destroyed.
- Cables are always to be laid in such a way that damage is excluded. Observe to fasten them tightly.
- Do not lay the 12 V cable with 230 v cables together in the same cable duct (conduit).
- Check live cables or leads periodically for insulation faults, points of break or loosened connections. Occurring defects must be remedied immediately.
- The unit is to be disconnected from any connection prior to execution of electrically welding or work on the electric system.
- If the non-commercial end-user is not able to recognize the characteristic values being valid for a unit or the regulations to be observed, a specialist is always to be consulted.
- The user/buyer is obliged to observe any construction and safety regulations.
- **Do not open the unit in any way! It contains no user-replaceable parts and can also contain dangerously high voltages for a long time (especially in case of faults) after separation from the battery!**
- Keep children away from the inverter and the batteries.
- Observe the safety regulations of the battery manufacturer.
- Non-observance may result in injury or material damage.
- The warranty period is 36 months from the purchase date (against presentation of the sales slip or invoice).
The warranty will be void in case of any inappropriate utilisation of the unit, if it is used beyond the technical specification, in case of improper operation or external intervention. We do not assume any liability for any damage resulting hereof. The liability exclusion is extended to any service being executed by third, which has not been ordered by us in writing. Service is to be effected exclusively by VOTRONIC Lauterbach.

Mounting:

Install the inverter **near the battery (batteries)** at a location being clean and protected from humidity. The unit can be installed in any position. The vent holes should never be covered (distance to the vent holes and air escape at the front and at the back: at least 20 cm) to ensure optimum cooling. If the inverter is installed in a storage space, the storage space must be equipped with a sufficient number of vent holes to ensure sufficient ventilation to the ambiance. Install the unit on an even and hard mounting surface. The four **rubber feet** are provided for reduction of vibration. **Never remove** the rubber feet.

Display Panel / Remote Control:

The display panel can be removed after removal of the two fastening screws to facilitate positioning of the inverter. It can be reinstalled later in the desired position (it can be rotated in steps by 90 °) and screwed down.

If the inverter had been installed at a difficultly accessible location, the display panel can also be used as remote control. Remove the control panel out of the unit, reconnect it to the unit using the control cable (length 5 m) and install it at the desired location.

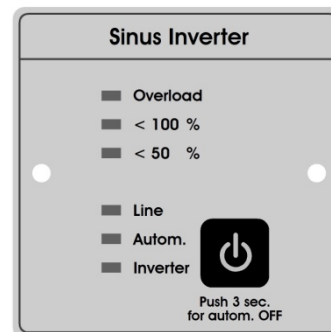

Capacity of the Battery (Ah):

Ensure that sufficient battery capacity is available to achieve optimum operation of the inverter. If a small consumer, such as a TV-set (approx. 50 Watts), is operated over the inverter, the load of the battery is only approx. 5 Amperes.

This means, that a battery capacity of e. g. 100 Ah allows an operation of many hours without any problems. But if the inverter is loaded with its nominal load, the current rate is many times higher (approx. 25 Amperes), and the operating time is reduced at the same battery capacity. This means, a small battery capacity reduces the operating time of large consumers significantly.

Connection to the Battery:



When connecting the inverter to the battery, a spark might occur for a short moment. Therefore, ensure sufficient ventilation during connection (explosive battery gas)!

The connection cable for the battery is designed for the capacity of the unit. Thus, please do not shorten. For exceptional cases, an extension of the two cables with a larger cross-section (6 or 16 mm²) is possible. In this case, the screwed connection between the original cable and the extension should be sound. **Always protect and cover this screwed connection because of the risk of short-circuit.**



The connection of the battery cable for the inverter should always be made with CORRECT POLARITY (+/-)! Wrong polarity might result in destruction of the unit!

A unit failure due to wrong polarity will be recognized and stored. This can be recognized in the factory at any time. This operating error **is not covered by the guarantee.**

Black Cable: - Negative Pole (Ground) to the negative pole of the battery (or Shunt of Batt.-Computer)

Red Cable: + Positive Pole (+12 V) over a **fuse** to the positive pole of the battery (cable protection)

It is highly recommended to **insert a fuse** into the plus line between battery and inverter to avoid **cable fires!** Fuse holder for strip fuse (order No. 2242) and strip fuse 80 A (order No. 2247) are available as accessories.

Connection Output Alternating Voltage (AC):



Observe the extremely dangerous supply voltage at the output of the inverter at the shockproof socket 230 V AC! Always observe the national installation regulations and the safety regulations concerning protection from electric shocks (protection against contact of live parts, insulation regulations).

Note: For reasons of safety and to avoid insulation faults of the connected units, as well as for universal applicability, the output (230 V AC) of the inverter is designed in such a way, that it is electrically isolated (completely isolated) from the battery side (DC) as well as from the housing. This means, it is neither earthed to phase nor to zero internally (protection class II).

During the stand-by mode, the inverter is not completely switched-off, but it will be "searching" from time to time!!



When being set to RunMode "Always On", the inverter can start automatically!!

It is therefore imperative to always separate the inverter from the 230 V consumers or the installation prior to execution of work at the 230 V consumers or the installation belonging to it (withdraw all plugs)!



Ensure that no external voltage reaches the output "Out" of the inverter. Otherwise the unit might be destroyed immediately.

Connection Plan 1:

Operation of a Consumer at the Inverter:

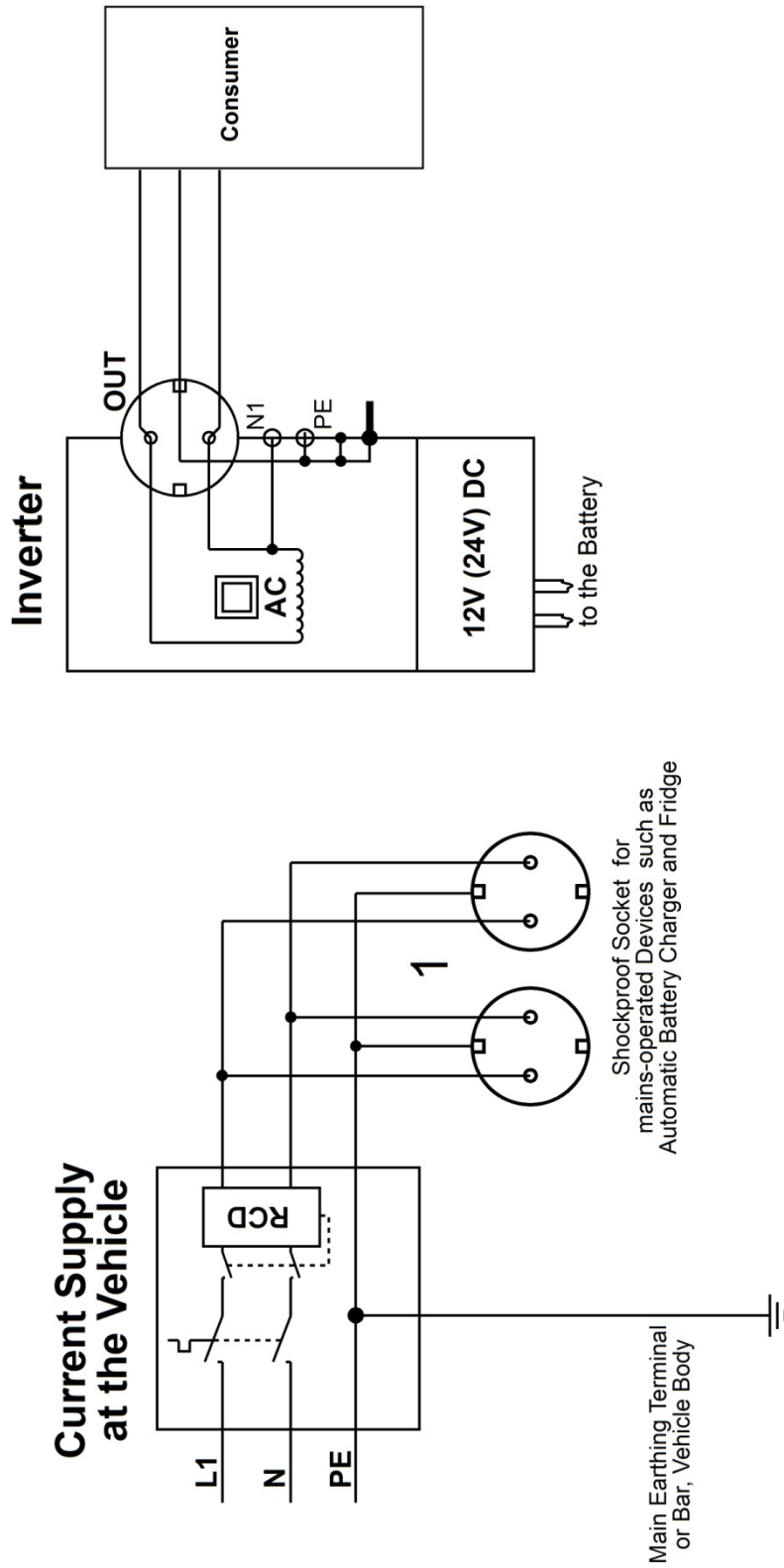

The consumer will be connected at the shockproof socket "OUT" of the unit.

Connection Plan 2:

Operation of Several Consumers at the Inverter via a Multi-Socket

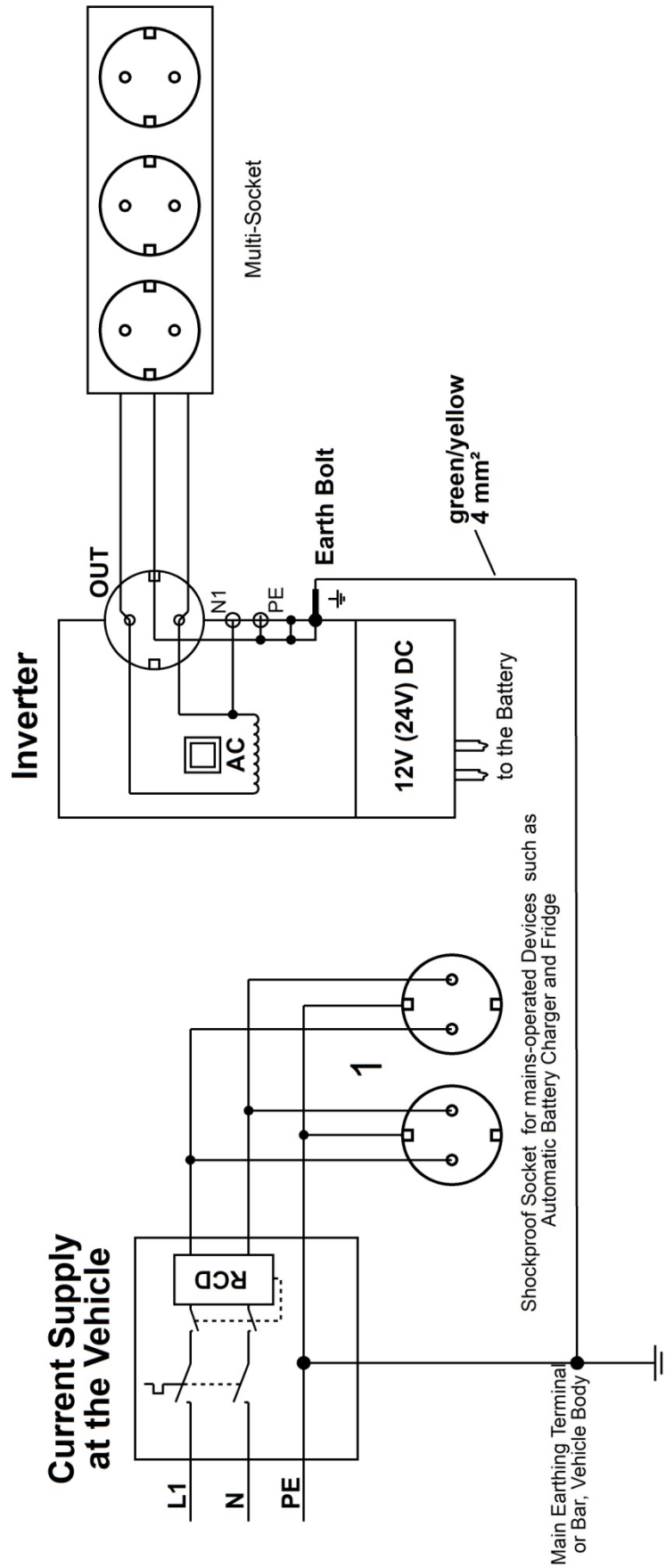

The multi-socket will be connected at the shockproof socket "OUT" of the unit. According to standards, the multi-socket should not be fixed installed, and the connection of the earth bolt at the inverter with the potential equalization cable 4 mm² green/yellow to the main earth terminal of the vehicle serves as protection from possible insulation faults of the connected units.

Start-up and Operation:

After the connection of the inverter to the 12 V battery, the inverter is ready for operation.

The unit is switched-on by momentarily pressing the ON/OFF switch (ON) at the display panel of the inverter (ON). The green light-emitting diode (LED) „**INVERTER**“ indicates the readiness for service. After an internal self-test of the entire system being indicated by 3 short beeps and one long beep, the inverter operation starts. 230 V alternating voltage (AC) is now supplied to the unit socket at the front panel for supply of the consumers.

Operation of the Inverter in Automatic Mode (Stand-by Mode):

The automatic mode helps to save battery energy in case of larger consumers. Very often, large consumers are switched-on for a short moment or in intervals due to their high power consumption, but the inverter permanently loads the battery, even if the consumer has already been switched-off (idle time)!!

This unnecessary battery load can be reduced by use of the stand-by function!

The inverter is started in **automatic mode** by momentarily pressing the ON/OFF switch, and the LEDs "INVERTER" and "AUTOM." will be lighting.

When being switched-on, the inverter checks the connected load continuously (e. g. TV-set). So, capacity is required, as long as the TV-set is switched-on (> 15 W, see below Adjustment of the "Load Threshold"). If the TV-set will be switched-off (< 15 W), the inverter will recognize this state, and it changes automatically to stand-by mode after a short observation time.

All light-emitting diodes will stop lighting, only the yellow LED „Autom.“ will be flashing every second. Now, the battery load is reduced to approx. 0.1A. The inverter checks every second, if any load (> 15 W) has been connected to the output. If the inverter does not find a consumer within the following 5 or 10 minutes (duration of the search is adjustable) during the stand-by mode, it will be switched-off completely, and it can only be restarted by means of the ON/OFF switch (safety measure).

Optimum adaptation of the stand-by mode to the corresponding requirements is achieved by setting the stand-by threshold (load) as well as the duration of the stand-by search run (time). Remove the display panel from the front panel and use the two switches for setting:



View: Display panel removed

- Switch 1 (Load):** Load Threshold 15 W or 60 W
- Switch 2 (Time):** Duration of the search run, 5 minutes or 10 minutes
- Switch 3 (PowerSave):** If desired by remote control can be switched-on/off or permanently off
- Switch 4 (Run Mode):** Operation by display panel / remote control or continuous operation



During the stand-by mode, the inverter is not completely switched-off!!

When being set to RunMode "Always On", the inverter can start automatically!!!

It is therefore imperative to always separate the inverter from the 230 V consumers or the installation prior to execution of work at the 230 V consumers or the installation belonging to it!

Operation of the Inverter without Automatic Mode (Stand-by Mode = OFF):

If the inverter shall be operated without automatic mode, which might be required for unproblematic operation of consumers with very low capacity, such as battery chargers, portable radios etc., the automatic mode must be deactivated. This can be effected in two different ways.

1. Permanent Setting:
Set switch 3 (PowerSave) to position OFF.
2. Setting can be selected when starting the inverter:
Push the ON/OFF switch for more than 3 seconds when starting the inverter. After this time, the yellow LED „AUTOM.“ will **stop lighting**, and the inverter is in continuous mode.



If the connected consumer is switched-off, the inverter will continue working (idle time), and it will load the battery permanently.

Operation of the Inverter in Permanent Continuous Operation:

If the inverter shall operate in permanent continuous operation, set switch 4 (RunMode) to position "Always ON". This switch position starts the inverter automatically, as soon as it is connected to 12 V battery voltage.



During this mode, the key of the display panel has no function. Operation of the inverter can be reactivated by setting switch 4.

Tips for Inverter Operation:

- The inverter itself only requires few current. Thus, the connected consumers determine the current consumption out of the battery. The longest possible operating time at the battery can be achieved by disconnection of the consumers being not required.
- If possible, the automatic mode (stand-by function) should be used to save energy.
- The real power consumption of some consumers, such as TV-sets being set to a very high brightness, is higher than the indicated nominal capacity.
- The power requirement of HiFi-systems with inferior volume is comparatively much lower than the indicated capacity.
- The power consumption for starting of some consumers is higher than during the continuous operation. If the continuous rating of these consumers is e. g. below 15 W, but the starting capacity exceeds 15 W, it might happen that these consumers are continuously switched-on and off during the automatic mode (stand-by function). In this case, the automatic mode should be deactivated, and the inverter should be switched-off manually after use.
- Operation of 230 V consumers only during driving or with running motor is possible by an ON/OFF control unit (control unit, order No. 2065) being available as accessory, which is switching the inverter automatically on and off over the D+ of the dynamo.
- Operation of the inverter with a second display panel or a second remote control is possible with an extension set with control cable of 5 m length, adapter and remote control being available as accessory (order No. 2067).

Connected Capacity of the Connected Consumers:

A safe operation requires, that the total of the nominal capacity rates (Watts) of the connected consumers (indication in "VA" or "W" on the nameplate or in the technical data of the corresponding appliance) does not exceed the nominal capacity of the inverter 600 W.

Please observe that the real current consumption of many 230 V appliances is higher than the value resulting from the active power, which is indicated in "W" on the nameplate.

It is also to be considered that almost all appliances are requiring a higher capacity during the starting phase (moment of starting) than during normal operation. The starting capacity can be **many times higher than the continuous rating!** For these appliances, the inverter can be loaded to well above its nominal capacity for a short-moment (refer to technical data).

Pilot Lamps Load/Overload and Overload Protection:

The load of the inverter is indicated by three light-emitting diodes (LED) at the control panel:

- The LED „< 50 %“ is lighting in green, if the load is approx. 10 / 20 Watts up to 50 % of the nominal capacity of the connected appliance.
- If the nominal capacity exceeds 50 %, the LED „< 100 %“ will be lighting in yellow.
- If the inverter is operated with **more than 100 %** of its nominal capacity, the red LED „**OVERLOAD**“ will be lighting. Additionally, an audible alarm will refer to the overload.

From an overload of 5 %, **the rhythm of the audible alarm will be slow**. During this operating state, the inverter will continue working; however, a disconnection of the inverter due to overtemperature can be expected in the long term.

From an overload of 15 %, **the rhythm of the audible alarm will be quick**. In case of this operating state, the inverter will be disconnected within the following 10 seconds. Now, the drawn capacity should immediately be reduced.

If the maximum duration for the overload is exceeded, the inverter will be switched-off. The green LED „**INVERTER**“ will stop lighting, the red LED „**OVERLOAD**“ will be flashing, and an audible signal is released. After reduction of the connected load or disconnection of consumers, the inverter can be restarted by actuating the ON/OFF switch.

Table Error Messages:

If the inverter is switched-off due to overload, this disconnection is additionally evaluated to describe the error clearly. The LED display indicates the criterion for disconnection as below:
(X = LED is flashing, O = LED is flashing depending on time and temperature, — = LED OFF):

Overload	< 100 %	< 50 %	Inverter	Type of Load	Audible Signal
X	X	X	- / O	A) Output bridge defective	Beep for 3 sec. - Pause
X	X	-	- / O	B) Short-circuit Output	2xShort Beeps - 1xLong Beep - Pause
X	-	-	- / O	c) Overload, Load Jump	6 x Beep - Pause
X	-	-	- / O	D) Overtemperature	8 x Beep - Pause
-	-	-	- / O	E) Low Voltage	4 x Beep - Pause
-	-	-	- / O	F) Overvoltage	2 x Beep - Pause
-	-	-	X	G) Internal Error	Beep Interval without Pause

Error Messages:

- A) The inverter has recognized a component failure. As long as the LED „**INVERTER**“ is flashing (approx. 1 minute), the inverter has not been cooled down sufficiently to be restarted. Switch-off all connected consumers and restart the unit. If the failure should be indicated several times (3 x), the inverter is defective. In this case, please contact our service address.
- B) The inverter has recognized a short-circuit or an operating state being similar to a short-circuit. (This might have been caused by connection of a consumer with very high starting current rates, and does not necessarily stand for a defective 230 V consumer). As long as the LED „**INVERTER**“ is flashing (approx. 1 minute), the inverter has not been cooled down sufficiently to be restarted. Switch-off all connected consumers and restart the unit. In this case, it should be observed to switch-on the consumers in the lowest power stage to ensure safe starting of the appliance. Increase the capacity step by step after that (e. g. vacuum cleaner). A possibility to start appliances with high starting current is to "run up" the inverter together with the consumer: First switch-on the corresponding consumer and after that the inverter. By this method, the inverter limits the maximum capacity of the consumer during starting. If the failure should be indicated at least 3 times, the inverter is defective and must be checked in the factory.
- C) The inverter has recognized an excessive load or load jump. Load jumps or high starting current rates are always an extreme load for the inverter. In order to prevent damage of the inverter by these characteristics, the inverter being already heated by load will be switched-off earlier than an inverter being cold. As long as the LED „**INVERTER**“ is flashing, the inverter has not been cooled down sufficiently to be restarted.
- D) A further measure for protection against continuous overload or insufficient cooling (see installation) is the internal temperature control (**protection against overheating**) for automatic disconnection of the inverter. An audible signal can be heard, the green LED „**INVERTER**“ will stop lighting, and the red LED „**OVERLOAD**“ will be flashing. The integrated cooling fan continues working. Permanent lighting of the red LED „**OVERLOAD**“ during operation indicates a premature disconnection of the inverter. Increased temperature is indicated by a **slow beep rhythm**. Further increase of the temperature will be indicated by a **quick beep rhythm**, and the inverter will be switched-off. Restart the unit by pushing the "ON/OFF" switch. If this should not be possible, restart it after a longer cooling-down phase.
- E) The battery is controlled by the inverter to prevent harmful total discharge of the battery:
 1. In case of dropped battery voltage, an audible signal (4 x "**Beep**") indicates imminent total discharge.
 2. In case of a **discharged battery**, an additional audible signal (4 x „**Beep**“) indicates imminent total discharge, and the inverter will be **switched-off automatically**.
 The inverter determines the switching thresholds **dynamically** from the battery load.
- F) The inverter protects itself against excessive battery voltage (>15 V) by automatic disconnection: The green LED „**INVERTER**“ will be flashing, and an audible signal (2 x „**Beep**“) can be heard.
- G) The self-test of the inverter has recognized an internal error or a condition beyond the limit values. Starting is not possible to prevent destruction of the inverter. The green LED „**INVERTER**“ will be flashing, and an audible signal (continuous „**Beep**“ interval) can be heard. In case of this failure, the unit can be restarted after approx. 10-15 minutes waiting time.
If the failure occurs more frequently, please contact the service address.

Notes:

Technical Data:	SMI 600 Sinus
Nominal Voltage Lead-Acid/Gel/AGM Battery (DC):	12 V
Nominal Voltage Lithium LiFePO4 Battery (DC):	12 V - 13.3 V
Input Voltage (DC):	(10.5 V - 15.5 V)
Recommended Minimum Battery Capacity:	> 80 Ah (depending on consumer)
Connection Cable Battery:	2 x 10 mm ² 1,2 m Length
Recommended Fuse Positive Pole Battery:	80 A
Output Voltage (AC):	230 V Pure Sine
Output Frequency:	50 Hz, crystal stabilized
Continuous Rating (30°C):	600 W
Momentary Capacity:	840 W
Peak Power:	1200 W
Power Consumption DC at Nominal Capacity:	56 A
Power Consumption DC at Overload max.:	90 A
CosPhi of the Consumers:	No Restriction
Overvoltage Battery max.:	16.0 V
Low Voltage Battery min.:	10.5 V (load-dependent, dynam.)
Own Consumption ON (without load) approx.:	6 W
Own Consumption During Stand-by (without load):	approx. 5 W
Criterion for Disconnection of Stand-by:	< 15 W / 60 W
Dwell Time for Stand-by:	30 Seconds
Duration During Stand-by:	5/10 Minutes
Overload Protection /Overtemperature Protection	Yes / Yes
Fan with Continuous Temp. Control:	Yes
System of Protection, Protection Classes:	IP21, II
Dimensions (mm):	305 x 160 x 71
Weight:	2200 g
Ambient Conditions, Humidity of Air:	max. 95 % RH, no condensation
Safety Regulations:	EN 62368-1



Declaration of Conformity:

In accordance with the provisions of Directives 2014/35/EU, 2014/30/EU, 2009/19/EC, this product complies with the following standards or normative documents:
EN55014-1; EN55022 B; EN61000-6-1; EN61000-4-2; EN61000-4-3; EN61000-4-4;
EN61000-4-5; EN62368-1; EN50498.



The product must not be disposed of in the household waste.



The product is RoHS compliant. It complies with the directive 2011/65/EU for Reduction of Hazardous Substances in electrical and electronic equipment.



Delivery Scope:	Available Accessories:	
<ul style="list-style-type: none">• Power Inverter• Installation and Operating Manual• Control Cable, 5 m Length, for Operation of the Display Panel as Remote Control	<ul style="list-style-type: none">- Control Unit- Extension Set with Second Remote Control- Fuse Holder for Strip Fuse <p>for SMI 600 Sinus:</p> <ul style="list-style-type: none">- Strip Fuse 80 A	<ul style="list-style-type: none">Order-No. 2065Order No. 2067Order No. 2242Order No. 2247

Subject to misprints, errors and technical modification without notice.

All rights reserved, particularly the right of reproduction. Copyright © VOTRONIC 07/2018.

Made in Germany by VOTRONIC Elektronik-Systeme GmbH, Johann-Friedrich-Diehm-Str. 10, 36341 LAUTERBACH / GERMANY

Phone: +49 (0)6641 / 91173-0 Fax: +49 (0)6641 / 91173-20 E-mail: info@votronic.de Internet: www.votronic.de